

# TSW030

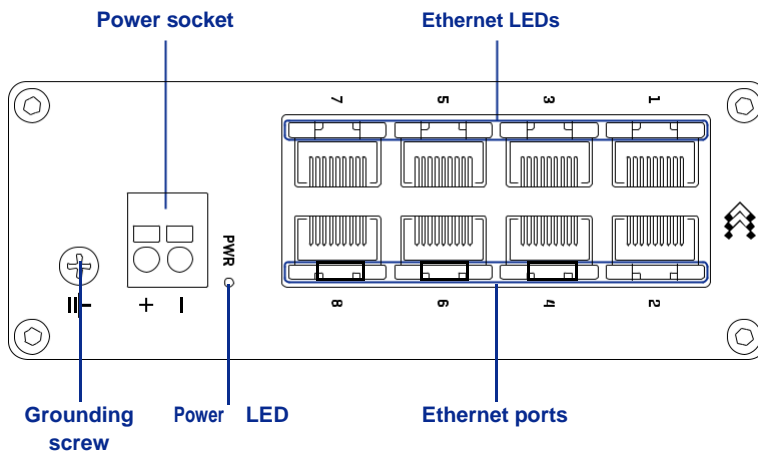

# HARDWARE

## FRONT VIEW



## BACK VIEW

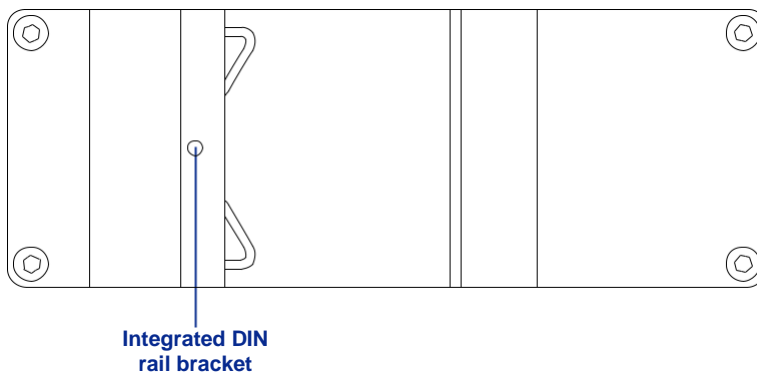

## RJ45 LED MEANING

Orange LED on: link established  
10/100 Mbps  
Orange LED blinking: active connection



## POWER SOCKET PINOUT



# FEATURES

## ETHERNET

Ethernet	8 x ETH ports, 10/100 Mbps, supports auto MDI/MDIX crossover
IEEE 802.3 series standards	802.3i, 802.3u, 802.3ab, 802.3x, 802.3az

## PERFORMANCE SPECIFICATIONS

Bandwidth (Non-blocking)	20 Gbps
Packer buffer	128 KB
MAC address table size	2K entries
Jumbo frame support	9216 bytes

## POWER

Connector	2-pin industrial DC power socket
Input voltage range	7 – 57 VDC, overvoltage protection: 60Vmax, reverse polarity protection: 80Vmax, surge protection: min 64.4V/max 71.2V breakdown voltage, 93.6V maximum reverse voltage @4.3A maximum reverse surge current, 1- Vin, 2-PGND
Power consumption	Idle: 0.5 W / Max: 1.5 W

## PHYSICAL INTERFACES

Ethernet	8 x RJ45 ports, 10/100 Mbps
Status LEDs	1 x Power LED, 16 x ETH status LEDs
Power	1 x 2-pin industrial DC power socket
Other	1 x Grounding screw

## PHYSICAL SPECIFICATION

Casing material	Anodized aluminum housing and panels
Dimensions (W x H x D)	113.1 x 41.2 x 74.6 mm
Weight	256 g
Mounting options	Integrated DIN rail bracket, wall mount, flat surface (additional kit needed)

## OPERATING ENVIRONMENT

Operating temperature	-40 °C to 75 °C
Operating humidity	10% to 90% non-condensing
Ingress Protection Rating	IP30

## REGULATORY & TYPE APPROVALS

Regulatory	CE, UKCA, EAC, UCRF, RCM, FCC, IC, CB
------------	---------------------------------------

## EMC EMISSIONS & IMMUNITY

EMI IMMUNITY	EN 55032:2015+A11:2020; EN 55035:2017+A11:2020; EN IEC 61000-3-2:2019+A1:2021; EN 61000-3-3:2013+A1:2019+A2:2021;
ESD	EN 61000-4-2:2009
Radiated Immunity	EN IEC 61000-4-3:2020
EFT	EN 61000-4-4:2012
Surge Immunity (AC Mains Power Port)	EN 61000-4-5:2014 + A1:2017
CS	EN 61000-4-6:2014
DIP	EN IEC 61000-4-11:2020

## SAFETY

Standards	IEC 62368-1:2018
-----------	------------------

## STANDARD PACKAGE\*

- TSW030
- QSG (Quick Start Guide)
- Packaging box



\* Standard package contents may differ based on standard order codes.

## CLASSIFICATION CODES

HS Code: 851762

HTS: 8517.62.00

For more information on all available packaging options – please contact us directly.

## AVAILABLE VERSIONS

HARDWARE VERSION	SUPPORTED FREQUENCIES	STANDARD ORDER CODE / PACKAGE CONTAINS
TSW030 *****	N/A	TSW030000000 / Standard package

## TSW030 SPATIAL MEASUREMENTS

### MAIN MEASUREMENTS

W x H x D dimensions for TSW030:

Device housing\*: 113.1 x 41.2 x 74.6 mm

Box: 118.5 x 45.7 x 79.5 mm



### ErreUno S.r.l.

Via Novella ,13  
 43058 Sorbolo (PR) Italy  
 Tel : +39 / 0521 694164  
 Fax: +39 0521-1851863  
 email: info@erre1.it  
 P.I / CF : 02379290345  
 RAE : 233443

