

# FPM-212 FPM-215 FPM-217 FPM-219

## 12" XGA/15" XGA/17" SXGA/19" SXGA Industrial Monitors with Resistive Touch Control, Direct HDMI, DP, and VGA Ports



### Features

- 12" XGA/17" SXGA TFT LED LCD with 50,000 backlight lifetime
- 15" XGA/19" SXGA TFT LED LCD with 70,000 backlight lifetime
- Direct HDMI, DP and VGA input interfaces
- Anti-glare screen with tempered glass
- Robust system with Die-casting aluminum chassis and IP66-rated aluminum alloy front bezel
- Lockable I/O connectors
- Slim design enables easy installation
- Supports various mount options: panel, desktop, and VESA arm

### Introduction

In IIoT and Industry 4.0, more and more customers need data to be visualized to help process management and decision making. The FPM-200 series is an industrial-grade monitor with sleek, simple lines and a true-flat touchscreen. Equipped with durable resistive touch control and an IP66-rated front bezel, FPM-200 series is designed for intuitive operation in industrial environments such as smart factory and machine automation display applications.

### Specifications

#### General

- **Certification** BSMI, CCC, CE, FCC Class A, UL
- **Dimensions (W x H x D)**
  - FPM-212: 311.8 x 238.0 x 53 mm (12.27 x 9.37 x 2.08 in)
  - FPM-215: 383.2 x 307.3 x 53.20 mm (15.08 x 12 x 2.09 in)
  - FPM-217: 410.4 x 343.4 x 54 mm (16.15 x 13.51 x 2.12 in)
  - FPM-219: 454 x 379.8 x 51.5 mm (17.87 x 14.95 x 2.03 in)
- **Enclosure** Front panel: Die cast magnesium alloy  
Rear cover: Die-casting aluminum
- **Mount Options** Stand, Wall, Panel and VESA arm (75 x 75mm)
- **Power Input** FPM-2XX-R8AE : External 36 W power adapter, with AC 100 V ~ 240 V input and DC +12 V @ 3 A output (included)  
FPM-2XX-R9AE: Terminal Block: 24 V<sub>DC</sub> input, (Optional 60W power adapter)
- **Video Port** HDMI, DP, and VGA
- **Weight (Net)** 3.2 kg / 4.6 kg / 5.4 kg / 6.2 kg

#### Power Consumption

- **FPM-212-R8AE** 17.91(idle), 19.01(Max)
- **FPM-215-R8AE** 14.69(idle), 15.32(Max)
- **FPM-217-R8AE** 12.04(idle), 14.56(Max)
- **FPM-212-R9AE** 16.65(idle), 17.51(Max)
- **FPM-215-R9AE** 14.19(idle), 14.75(Max)
- **FPM-217-R9AE** 11.92(idle), 14.19(Max)
- **FPM-219-R9AE** 14.19(idle), 15.53(Max)

#### LCD Display

- **Display Type** XGA/XGA/SXGA/SXGA TFT LCD
- **Display Size** 12"/15"/17"/19"
- **Max. Resolution** 1024 x 768/1024 x 768/1280 x 1024/1280 x 1024
- **Max. Color** 16.2M/16.2M/16.7M/16.7M
- **Viewing Angle (H/V °)** 178/178, 176/176, 170/160,170/160
- **Luminance (cd/m<sup>2</sup>)** 600/300/250/350
- **Backlight Life** 50,000/70,000/50,000/70,000 hr
- **Contrast Ratio** 1000:1 / 2000:1 / 1000:1/1000:1

#### Touchscreen

- **Type** 5-wire analog resistive
- **Interface** USB
- **Light Transmission** Above 75%
- **OS Support** Windows XP, Vista,7, 8,10,XPe and Linux

#### Environment

- **Operating Temperature** 0 ~ 50 °C (32 ~ 122 °F)
- **Storage Temperature** -20 ~ 60 °C (-4 ~ 140 °F)
- **Humidity (Storage)** 10 ~ 90% non-condensing
- **IP Rating** IP-66 graded front panel
- **Vibration** 5 ~ 500 Hz, 1 Grms (Operating, Random)

## Dimensions

Unit: mm

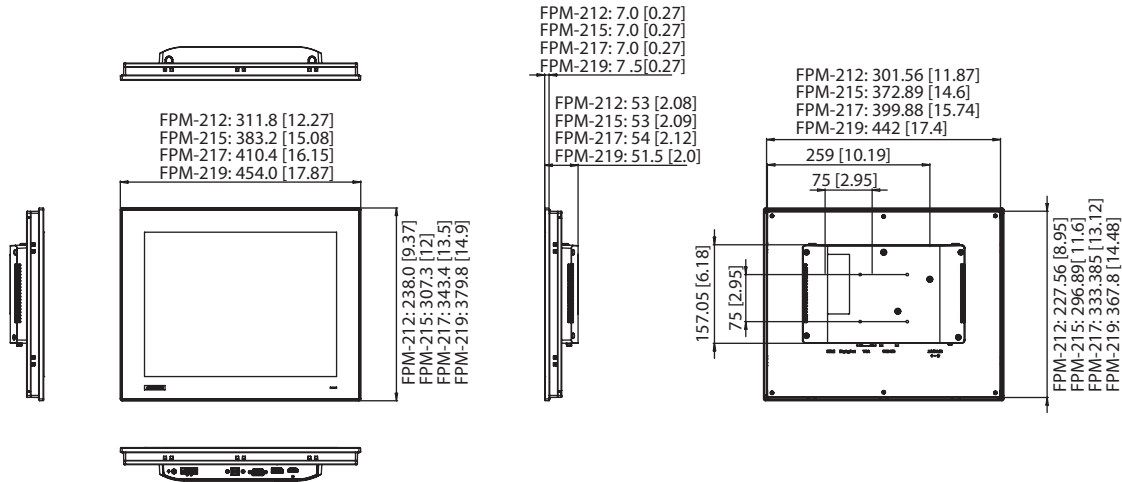

**Panel Cutout Dimensions:** FPM-212: 303 x 229 mm (11.93 x 9.02 in)  
 FPM-215: 374.5 x 298.5 mm (14.74 x 11.75 in)  
 FPM-217: 401.3 x 334.8 mm (15.8 x 13.18 in)  
 FPM-219: 443.5 x 369.3 mm (17.46 x 14.53 in)

## Ordering Information

- **FPM-212-R8AE** 12.1" XGA Ind. Monitor, w/Resistive TS
- **FPM-215-R8AE** 15 XGA Ind. Monitor, w/Resistive TS
- **FPM-217-R8AE** 17" SXGA Ind. Monitor, w/Resistive TS
- **FPM-212-R9AE** 12.1" XGA Ind. Monitor, w/Resistive TS (24 V<sub>DC</sub>)
- **FPM-215-R9AE** 15 XGA Ind. Monitor, w/Resistive TS (24 V<sub>DC</sub>)
- **FPM-217-R9AE** 17" SXGA Ind. Monitor, w/Resistive TS (24 V<sub>DC</sub>)
- **FPM-219-R9AE** 19" SXGA Ind. Monitor, w/Resistive TS (24 V<sub>DC</sub>)
- **96PSA-A60W24T2-3** Adapter 100-240V 60W 24V (Optional for 24 V<sub>DC</sub> models only)

## Front View



## Optional Accessories

- **1700001524** Power Cable US Plug, 1.8m
- **170203183C** Power Cable EU Plug, 1.8m
- **170203180A** Power Cable UK Plug, 1.8m
- **1700008921** Power Cable JP Plug, 1.8m
- **1700019146** Power Cable China/Australia Plug, 1.8m
- **FPM-1000T-SMKE** Desktop/Wall Mounting kit for FPM series

## I/O View

### I/O View (12VDC)

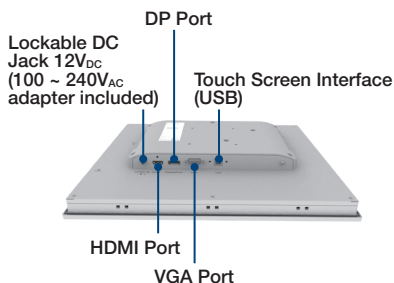

### I/O View (24VDC)

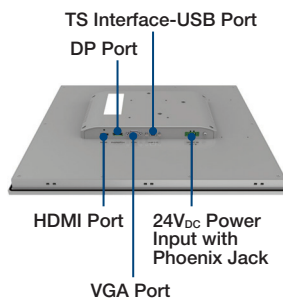

## Rear View

### Rear View (12VDC)

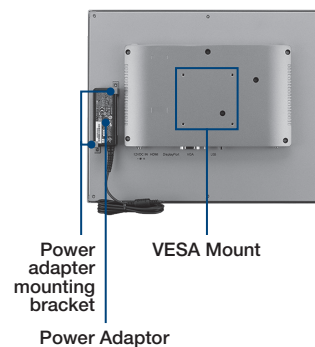

### Rear View (24VDC)

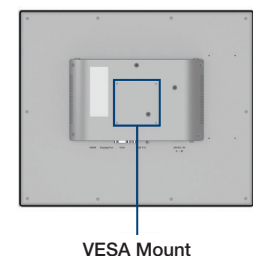

# FPM-221W

## 21.5" Full HD Industrial Monitor with P-CAP Touch Control, Direct HDMI Port



### Features

- 21.5" Full HD TFT LED LCD with true-flat touchscreen
- 16:9 wide screen aspect ratio, increases viewing area by 40%
- Supports 10-point multi-touch control via USB interface in Windows 7/8/10 OS
- Slim design enables easy installation
- Supports various mount options: panel, desktop, and VESA arm
- Touchscreen with reliable glass surface and P-CAP touch control
- Robust system with Die-casting aluminum chassis and IP66-rated aluminum alloy front bezel
- Lockable I/O connectors



### Introduction

In IIoT and Industry 4.0, more and more customers need data to be visualized to help process management and decision making. The FPM-221W is an industrial-grade, widescreen monitor with sleek, simple lines and a true-flat touchscreen. Equipped with P-CAP 10-point multi-touch control and an IP66-rated front bezel, FPM-221W is designed for intuitive operation in industrial environments such as smart factory and machine automation display applications.

### Specifications

#### General

- **Certification** BSMI, CCC, CE, FCC Class A, UL, CB
- **Dimensions (W x H x D)** 558.4 x 349.8 x 56.2 mm (21.98 x 13.77 x 2.21 in)
- **Enclosure** Front panel: Die-casting aluminium, Rear cover: Die-casting aluminium
- **Mounting** Panel, VESA arm
- **Power Input** External 60 W power adapter, with AC 100 V ~ 240 V input and DC +12 V @ 5 A output (included)
- **Video Port** HDMI
- **Weight (Net)** 6 kg (13.23 lb)

#### LCD Display

- **Display Type** Full HD TFT LED LCD
- **Display Size** 21.5"
- **Max. Resolution** 1920 x 1080
- **Max. Color** 16.7M
- **Viewing Angle (H/V)°** 178/178
- **Luminance (cd/m<sup>2</sup>)** 250
- **Backlight Life (hrs)** 50,000
- **Contrast Ratio** 1000:1

#### Touchscreen

- **Type** Projected capacitive touch
- **Interface** USB
- **OS Support** Windows® 7, 8, 10, XPe, CE and Linux
- **Hardness** 7H
- **Multi Touch** 10 points, USB interface in Win 7/8/10, Linux

#### Environment

- **Operation Temperature** 0 ~ 50°C (32 ~ 122°F)
- **Storage Temperature** -20 ~ 60°C (-4 ~ 140°F)
- **Humidity (Storage)** 10 ~ 95% non-condensing
- **Waterproof** Front Panel IP66 Compliant
- **Vibration** 5 ~ 500 Hz, 1 Grms (Operating, Random)

### Ordering Information

- **FPM-221W-P4AE** 21.5" Full HD Industrial Monitor with PCAP Touch Control, Direct HDMI Input (Adapter included)
- **FPM-221W-P1AE** 21.5" Full HD Industrial Monitor with PCAP Touch Control, Direct VGA Input (Adapter included)

## Dimensions

Unit: mm

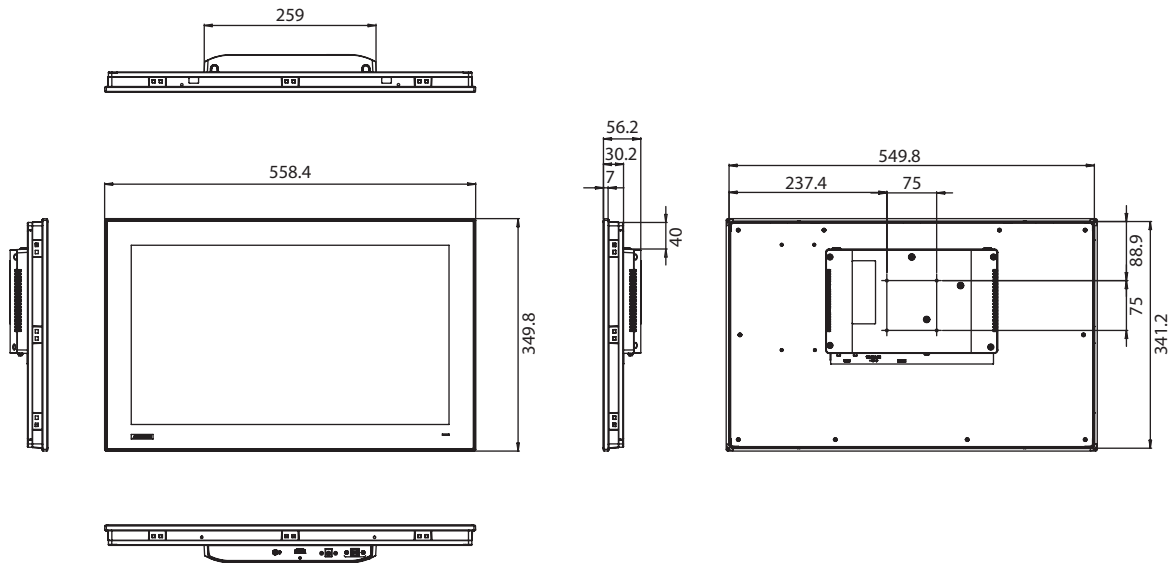

**Cut-out Dimensions: 550.30 x 341.8 mm (21.67 x 13.46 in)**

## Optional Accessories

- **FPM-1000T-SMKE** Desktop Mounting kit for FPM series
- **1702002605** Power Cable EU Plug 1.8 M
- **1702031801** Power Cable UK Plug 1.8 M
- **1700000596** Power Cable China/Australia Plug 1.8 M
- **1702002600** Power Cable US Plug 1.8 M
- **FPM-200W-ADKE** Adapter bracket for FPM-200W

## Front View



## Rear View

